

GEO-SEQ Project

Numerical Model Comparison Study for Greenhouse Gas Sequestration in Coalbeds

David H.-S. Law

Alberta Research Council (ARC) Inc.
Edmonton, Alberta, Canada

GEO-SEQ Project: Website

The screenshot shows a Netscape browser window titled "The GEO-SEQ Project - Netscape". The address bar displays "http://esd.lbl.gov/GEOSEQ/". The website content includes a large "GEO-SEQ" logo, a navigation menu with links like "Cost Optimization", "Capacity Assessment", "Monitoring Technology", "Public Outreach", "Performance Assessment Models", and "What's New". Below the logo, it states "A National Energy Technology Laboratory (NETL) Sponsored Project". The main heading is "Welcome to the GEO-SEQ Project". The text describes the project as a public-private R&D partnership for CO₂ sequestration by 2015. A bulleted list highlights key goals: lowering sequestration costs, developing monitoring technologies, and improving capabilities. At the bottom, logos for OML, Lawrence Livermore National Laboratory, and NETL are visible.

GEO-SEQ
A National Energy Technology Laboratory (NETL) Sponsored Project

Project

Cost Optimization Capacity Assessment Code Intercomparison
Monitoring Technology Public Outreach
Performance Assessment Models What's New ★

Collaborators | Industry Partners | Laboratory Partners | The Team
Organization Chart | Bibliography | Publications | Related Sites | Home

Welcome to the GEO-SEQ Project

GEO-SEQ (pronounced GEO-SEEK) is a public-private research and development (R&D) partnership that will deliver the technology and information needed to enable the application of safe and cost-effective methods for geologic sequestration of CO₂ by the year 2015.

The GEO-SEQ R&D plan was developed to address the need for improved tools and technologies for cost optimization, monitoring, modeling and capacity estimation. Taken together, significant advances in these areas will lay the

- Procedures for lowering the cost of sequestration by understanding the trade-offs among the costs of separation, compression, transportation and well-field and geologic considerations;
- An optimized set of monitoring technologies ready for full-scale field demonstration in three years in oil, gas, and brine formations, and two years later in coal formations;
- Improved capability of and

oml Lawrence Livermore National Laboratory NETL

<http://esb.lbl/GEOSEQ/>

COAL-SEQ I, Houston, Texas, U.S.A., March 14-15, 2002

GEO-SEQ Project

Task C-1

Enhancement of Numerical Simulators for
Greenhouse Gas Sequestration in Deep,
Unminable Coal Seams

- Part I: Pure CO₂ Injection
- Part II: Flue Gas Injection

GEO-SEQ Project

Task C-1: Approach

- Identify potential participants with coalbed methane (CBM) simulators
 - CBM simulators accessible to research team
 - Invitation to other interested groups
- Work with participants to setup problem sets
- Compare numerical results from different CBM simulators based on problem sets
- Document numerical solutions
- Identify areas of improvement for different CBM simulators
- Provide field data for validation of CBM simulators



Modification of Numerical Models

Coalbed Methane (CBM) Recovery Processes

Primary CBM Recovery:

- Dual porosity nature of coalbed
- Darcy flows of gas and water in the natural fracture system in coal
- Diffusion of a single gas component from the coal matrix to the natural fracture system
- Adsorption/desorption of a single gas component at the coal surface
- Coal matrix shrinkage due to gas desorption

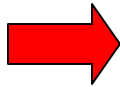

Enhanced CBM Recovery:

- Coal matrix swelling due to CO₂ adsorption on the coal surface
- Compaction/dilation of the natural fracture system due to stresses
- Diffusion of multiple gas components from the coal matrix to the natural fracture system
- Movement of water between the coal matrix and the natural fracture system
- Adsorption/desorption of multiple gas components at the coal surface
- Non-isothermal adsorption due to different in temperature between the coalbed and the injected CO₂



Problem Sets for Model Comparison

Part I: Pure CO₂ Injection

Model Attributes Tested	1 (Single Well)	2 (5-spot)	3 (5-spot)	4 (5-spot)	5 (Field Test)
Two Gas Components	✓	✓	✓	✓	✓
Dual Porosity Approach	✗	✗	✓	✗	✓
Mixed Gas Diffusion (Different Diffusion Rates)	✗	✗	✓	✗	✓
Mixed Gas Sorption (Extended Langmuir Model)	✓	✓	✓	✓	✓
Stress Dependent Permeability & Porosity	✗	✗	✗	✓	✓
Coal Shrinkage (Primary Process)	✗	✗	✗	✓	✓
Coal Shrinkage/Swelling (ECBM Processes)	✗	✗	✗	✗	✓

Participating Numerical Models

- Commercial models
 - GEM
 - Computer Modelling Group (CMG), Calgary, Alberta, Canada
 - ECLIPSE
 - Schlumberger GeoQuest, Abingdon, United Kingdom
 - SIMED II
 - CSIRO, Sydney, Australia/TNO, Utrecht, The Netherlands
 - COMET 2
 - Advanced Resources International (ARI), Arlington, Virginia, U.S.A.
- Non-Commercial model
 - GCOMP
 - BP, Houston, Texas, U.S.A.



Acknowledgement

- GEM
 - Peter Sammon, CMG
 - Long Nghiem, CMG
 - Mohamed Hassam, CMG
- ECLIPSE
 - Jim Bennett, GeoQuest
 - Sridhar Srinivassen, GeoQuest
 - Tim Hower, Malkewicz Hueni Associates
- SIMED II
 - Bert van der Meer, TNO
 - Xavier Choi, CSIRO
- COMET2
 - Larry Pekot, ARI
 - Scot Reeves, ARI
- GCOMP
 - John Mansoori, BP
 - Mel Miner, Marlet Consulting



Numerical Models

Features for ECBM Modelling

CBM Simulators	GEM	ECLIPSE	SIMED II	COMET 2	GCOMP
Multiple Gas Components (3 or more: CH ₄ , CO ₂ & N ₂)	✓	✗	✓	✓	✓
Dual Porosity Approach	✓	✓	✓	✓	✗
Mixed Gas Diffusion (Different Diffusion Rates)	✓	✓	✓	✓	✗
Mixed Gas Sorption (Extended Langmuir Model)	✓	✗	✓	✓	✓
Stress Dependent Permeability & Porosity	✓	✓	✓	✓	✓
Coal Shrinkage (Primary Process)	✓	✗	✓	✓	✓
Coal Shrinkage/Swelling (ECBM Process)	✓	✗	✓	✓	✓

Model Comparison

Problem Sets Completed

Part I: Pure CO₂ Injection

- Problem Set 1: single well CO₂ injection test
- Problem Set 2: 5-spot CO₂ injection process



CO₂ Sequestration in Coalbeds

Problem Set 1: Single Well CO₂ Injection Test

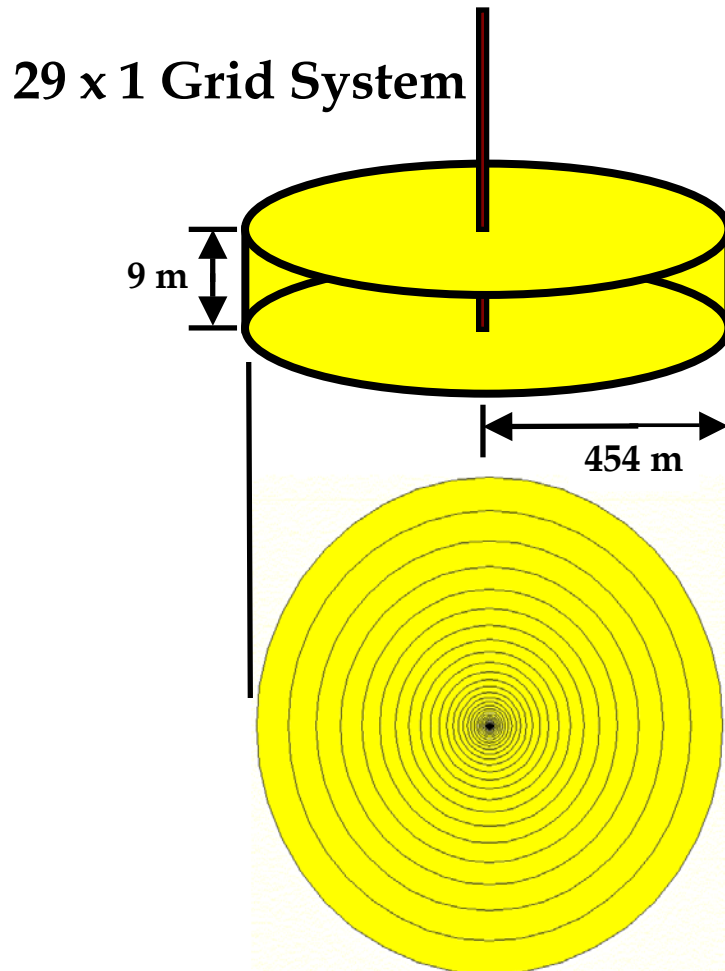

- 15-day CO₂ injection period
 - Injection rate = 28,316.82 sm³/d
- 45-day shut-in period
- 60-day production period
 - BHP = 275 kPa
- 62.5-day shut-in period
- Total test period = 182.5 days



Problem Set 1: Single Well CO₂ Injection Test

Well Bottom-hole Pressure

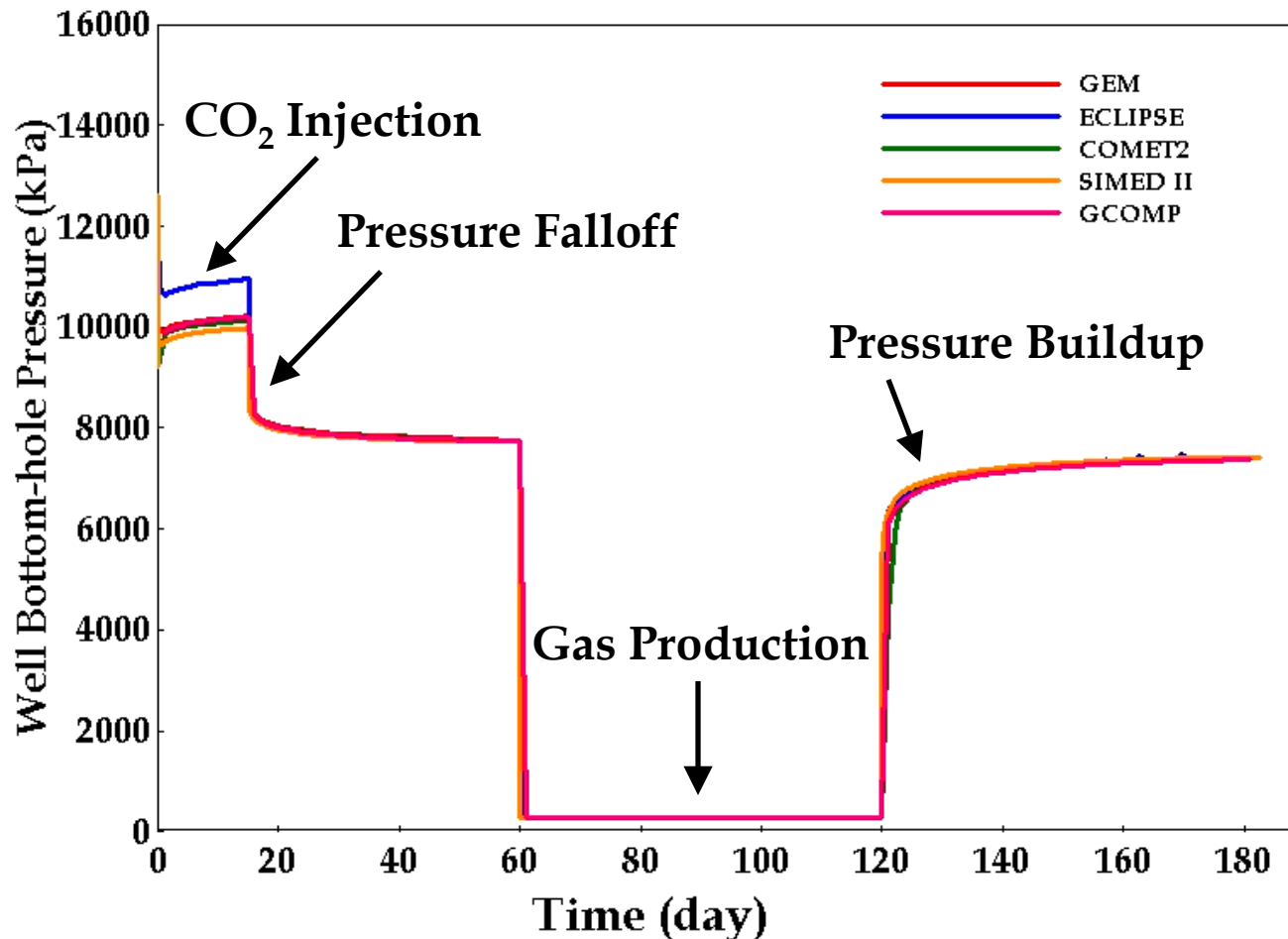

CO₂ Sequestration in Coalbeds

Problem Set 2: 5-Spot CO₂ Injection Process

1/4 of 2.5-acre 5-Spot Pattern

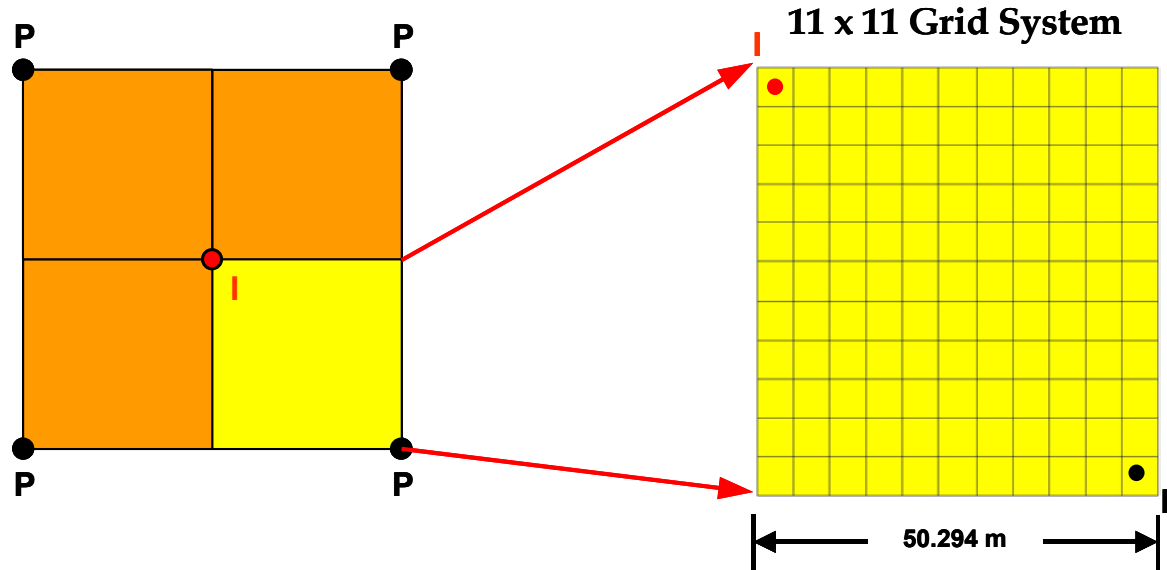

- 182.5-day continuous CO₂ injection period
 - Injection rate = 28,316.82 sm³/d
- 182.5-day production period
 - BHP = 275 kPa



Problem Set 2: 5-Spot CO₂ Injection Process

CH₄ Production Rate

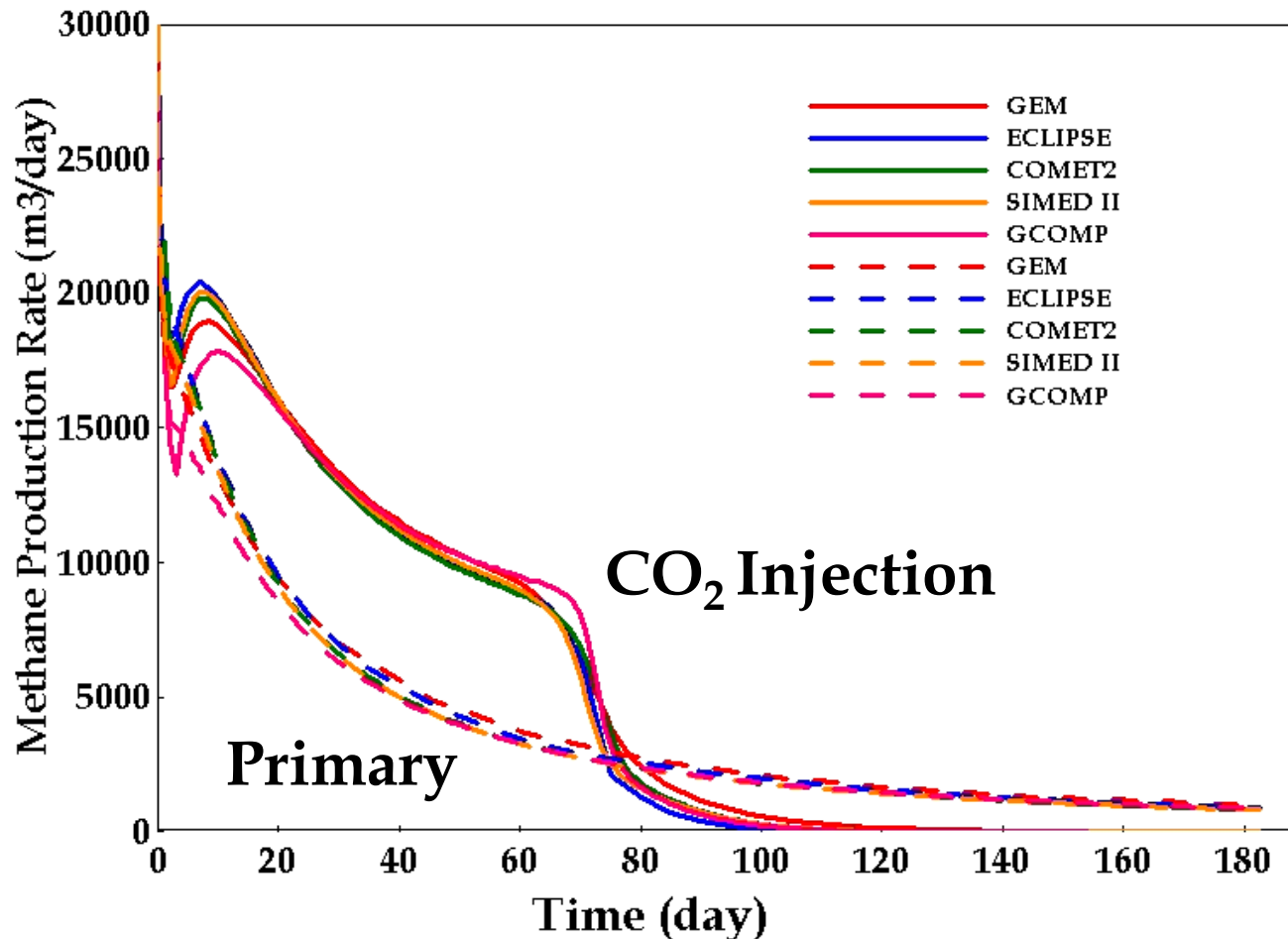

Problem Set 2: 5-Spot CO₂ Injection Process

CO₂ Distribution

CO₂ Mole Fraction in Gas Phase in Fracture

GEM

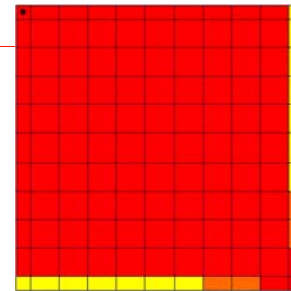
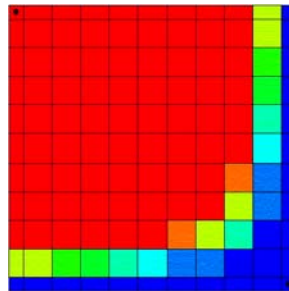
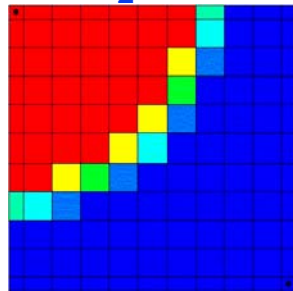

ECLIPSE

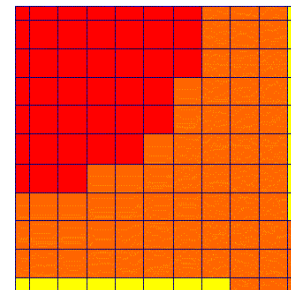
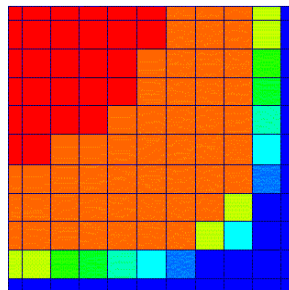
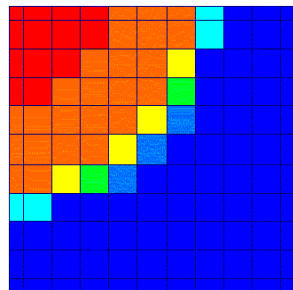

COMET2

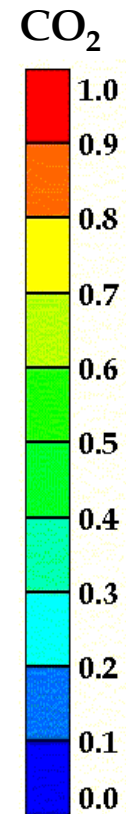
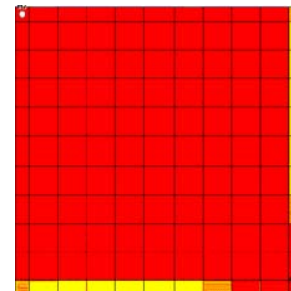
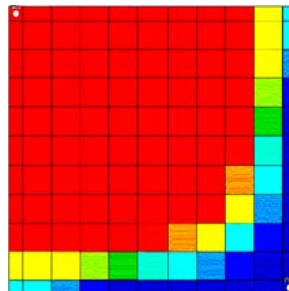
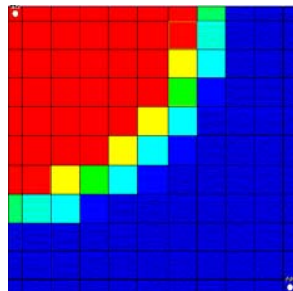

30 days

60 days

90 days



Conclusions on Model Comparison

Problem Sets 1 and 2

- In general, there are good agreement between the results from different numerical models
 - Baseline runs have been established for different numerical models which will be compared based on more complex problem sets
- Frequent communication with participants is essential to eliminate errors in data entry
- Difference between numerical prediction may results in a variety of reasons:
 - Handling of dual porosity approach in the model
 - Handling of wells (e.g., $\frac{1}{4}$ well in 5-spot pattern)
 - Selection of numerical control parameters



Publication

Problem Sets 1 and 2

- SPE Paper No. 75669 entitled “Numerical Simulation Comparison Study for Enhanced Coalbed Methane Recovery Processes, Part I: Pure Carbon Dioxide Injection”, was accepted for presentation at the SPE/CERI Gas Technology Symposium (GTS) 2002, Calgary, Alberta, Canada, April 30-May 2, 2002



Model Comparison

Problem Sets In Progress

Part I: Pure CO₂ Injection

- Problem Set 3: 5-spot CO₂ injection process
 - Effect of desorption time constant
- Problem Set 4: 5-spot CO₂ injection process
 - Effect of stress dependent permeability



Problem Set 3: 5-Spot CO₂ Injection Process

Effect of Desorption Time Constant

$$\frac{1}{t_{des}} = \sigma D_c$$

D_c : Diffusion coefficient (m²/d)

t_{des} : Desorption time constant (d)

σ : Geometric factor (1/m²)

For Example:

$$\sigma = 4 \left(\frac{1}{l_x^2} + \frac{1}{l_y^2} + \frac{1}{l_z^2} \right)$$

Kazemi



Problem Set 3: 5-Spot CO₂ Injection Process

Effect of Desorption Time Constant

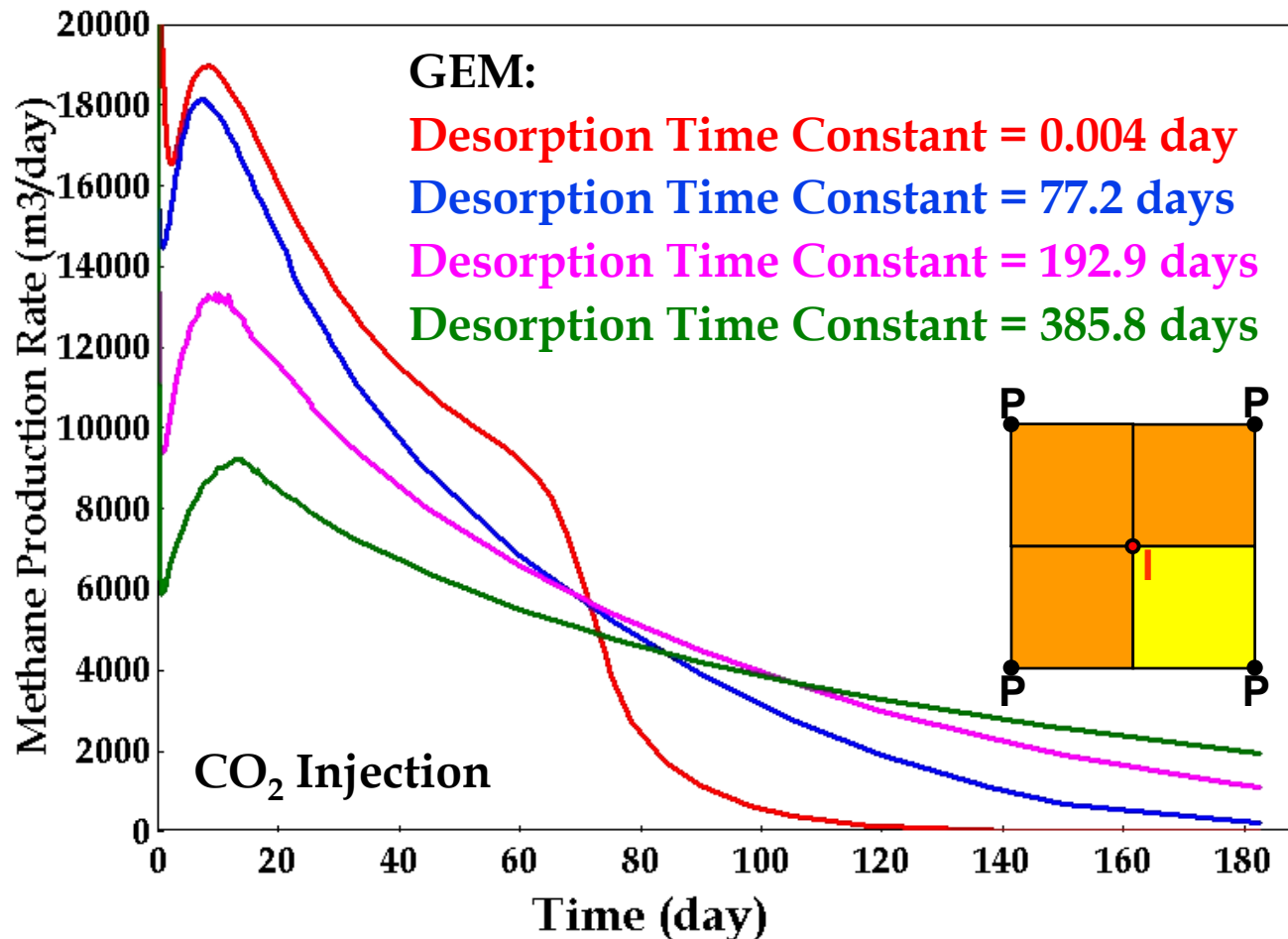

Problem Set 4: 5-Spot CO₂ Injection Process

Effect of Stress Dependent Permeability

Palmer & Mansoori Theory (1996)

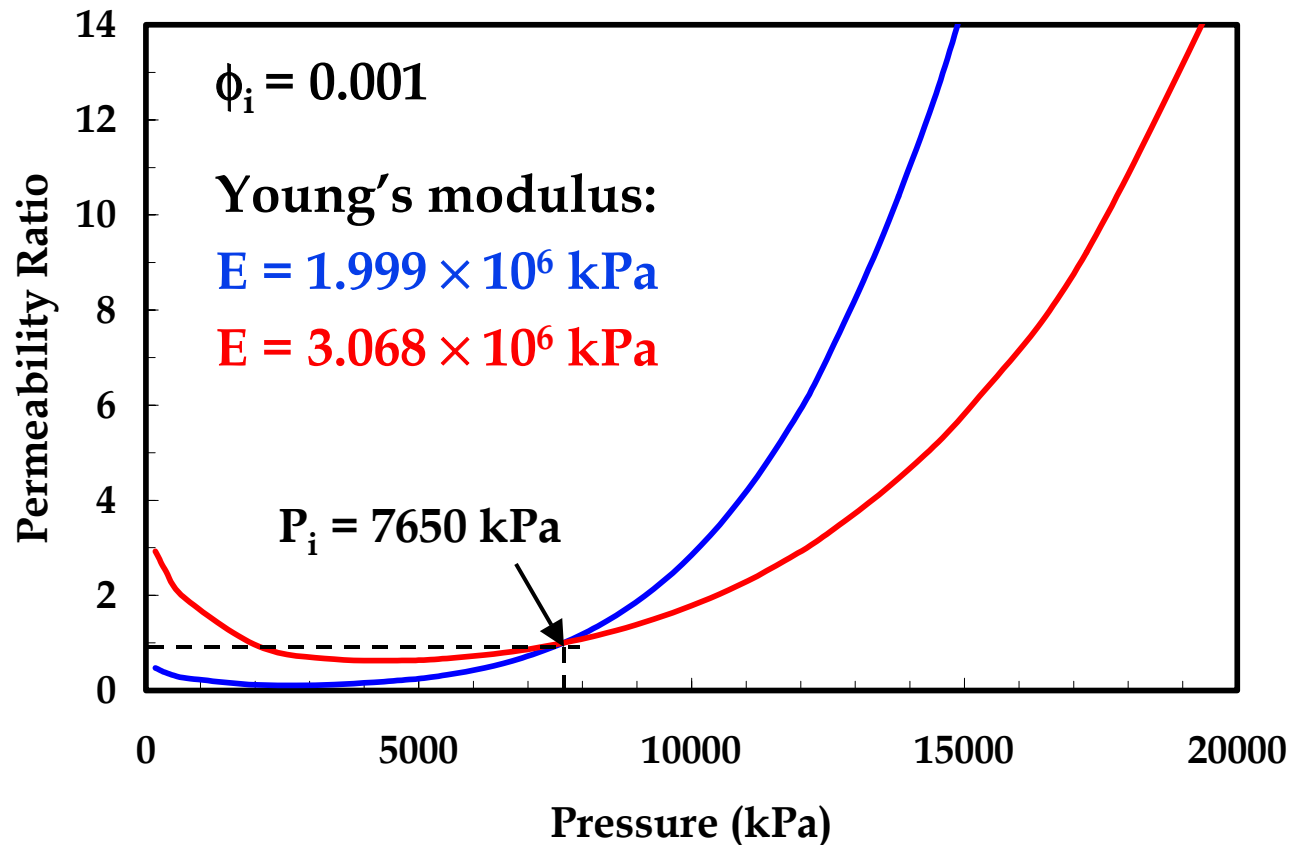

Problem Set 4: 5-Spot CO₂ Injection Process

Effect of Stress Dependent Permeability

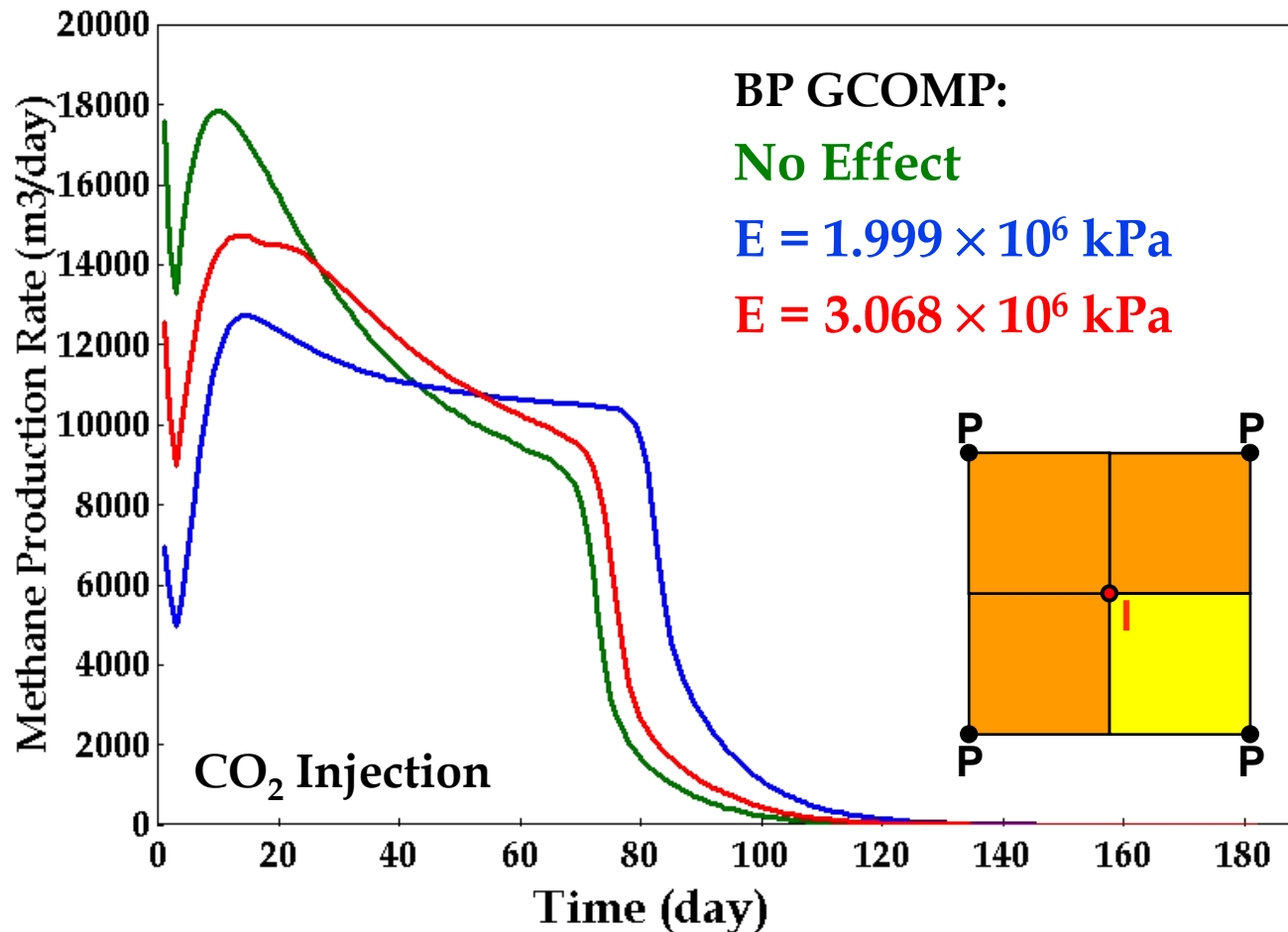

Model Comparison

Problem Set In Progress

Part I: Pure CO₂ Injection

- Problem Set 5: history matching of field data
 - ARC's Micro-Pilot with CO₂ Injection
 - Confidential data involved

Alberta Research Council (ARC) Greenhouse Gas Sequestration Project Fenn Big Valley, Central Alberta, Canada

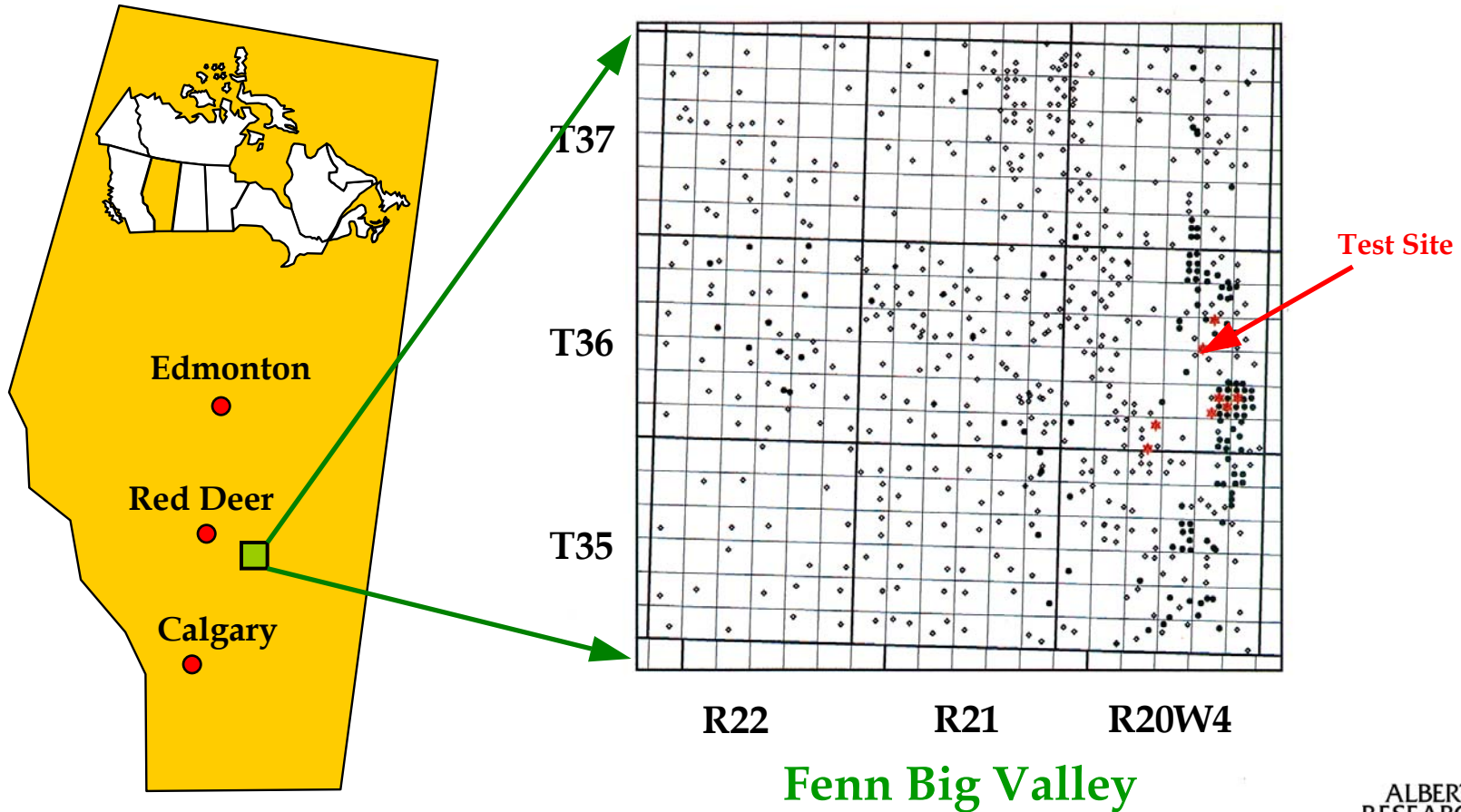

Problem Set 5: History Matching of Field Data

ARC's Micro-Pilot with CO₂ Injection

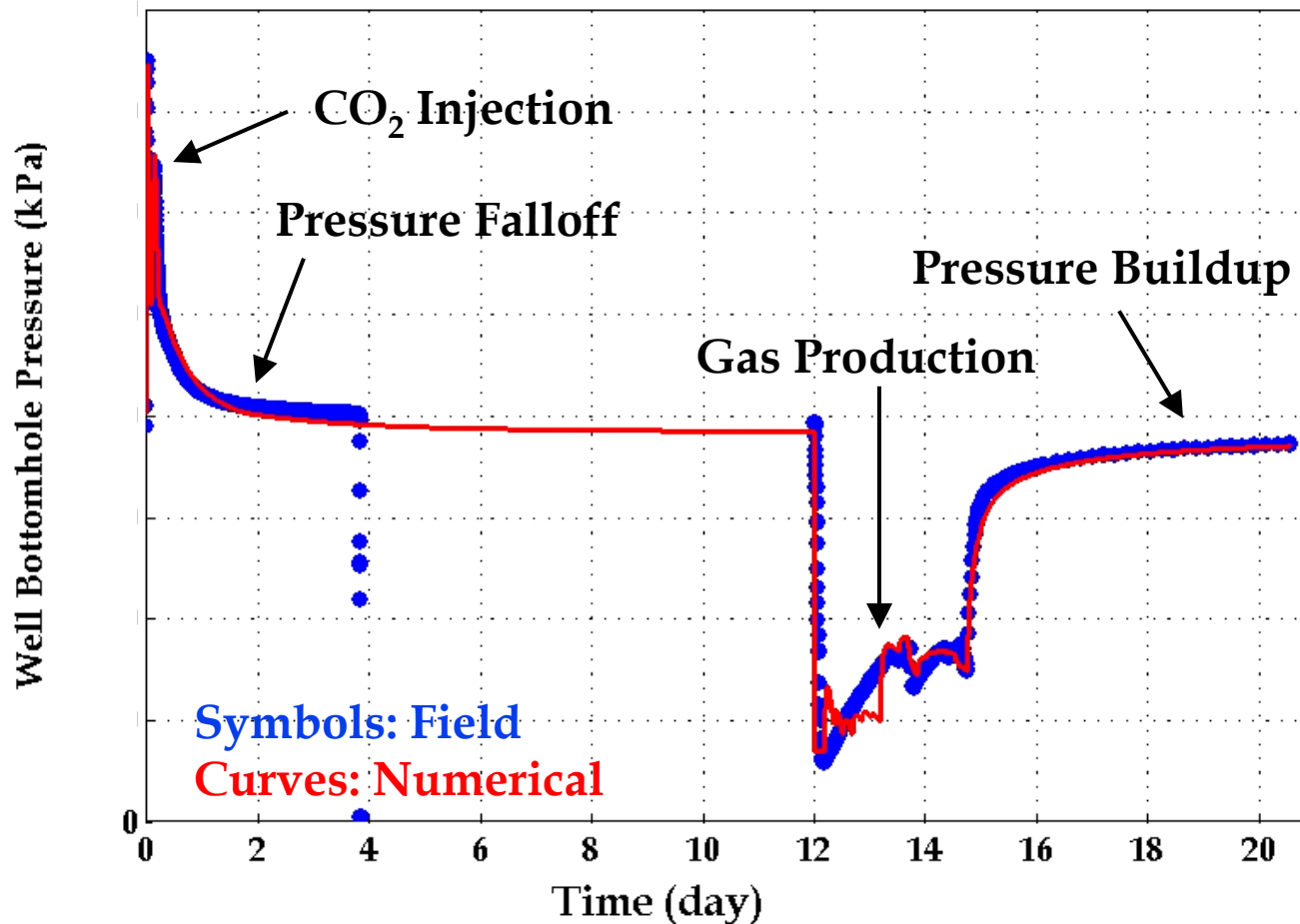

GEO-SEQ Task C-1: Web Site

Extranet - Netscape

File Edit View Go Communicator Help

Back Forward Reload Home Search Netscape Print Security Shop Stop

Bookmarks Location: <http://www.arc.ab.ca/extranet/ecbm/> What's Related

Enhanced Coalbed Methane Workgroup

The purpose of this site is to provide Workgroup members password protected access to information. To maintain confidentiality, the password will be changed periodically. Below you will find four main headings to help you navigate the site.

- [News](#)
- [Experimental Data](#)
- [Field Data](#)
- [Numerical Modelling](#)

To access the information please contact:

[David Law](#) Tel: (780) 450-5034
[Bill Gunter](#) Tel: (780) 450-5467

Problems accessing links, contact:

[Stacey Schaub-Szabo](#) Tel: (780) 450-5360.

Document: Done

<http://www.arc.ab.ca/extranet/ecbm/>

